

INSTRUCTION MANUAL

AKKU ULTRACORE FIT 48 V

500081 | 500256

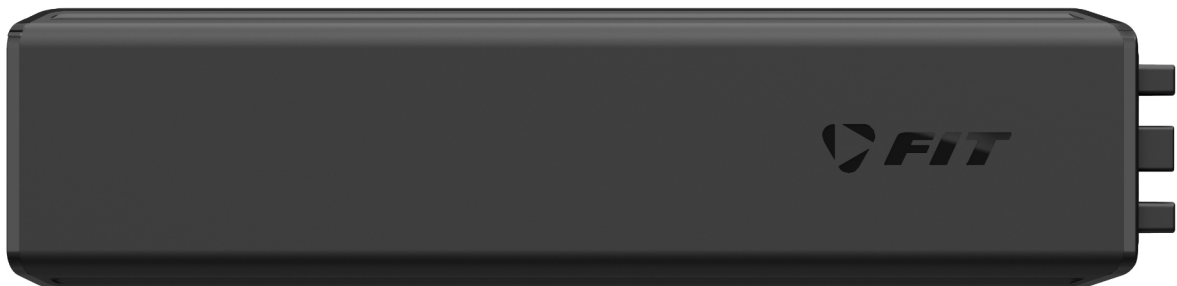

NETWORKED
CUSTOMISED
INTELLIGENT

TABLE OF CONTENTS

1	PREFACE	4
2	ABOUT THESE OPERATING INSTRUCTIONS	5
2.1	MANUFACTURER	5
2.2	LANGUAGE	5
2.3	DECLARATION OF CONFORMITY	5
2.4	ON INFORMATION	5
2.5	WARNINGS IN THESE OPERATING INSTRUCTIONS	5
3	SAFETY INSTRUCTIONS	6
3.1	GENERAL INFORMATION	6
3.2	RECHARGEABLE BATTERY	6
4	PRODUCT AND TECHNICAL SPECIFICATIONS	7
4.1	ULTRACORE FIT 48 V	7
4.2	PROPER USE	7
4.3	IMPROPER USE	7
4.4	TECHNICAL DATA	7
4.4.1	ULTRACORE FIT 48	7
5	TRANSPORTATION AND STORAGE	8
5.1	TRANSPORTATION	8
5.1.1	TRANSPORTING E-BIKES	8
5.1.2	TRANSPORTING THE BATTERY	8
5.1.3	SHIPPING THE BATTERY	8
5.2	STORAGE	8
5.2.1	STORAGE MODE	8
5.3	BREAK IN OPERATION	9
5.3.1	PREPARING FOR A BREAK IN OPERATION	9
5.3.2	CARRYING OUT A BREAK IN OPERATION	9
6	FITTING	10
6.1	FITTING THE BATTERY	10
6.1.1	REMOVING THE BATTERY	10
6.1.2	INSERTING THE BATTERY	10
7	OPERATION	11
7.1	CHARGING THE BATTERY	11
7.1.1	CHARGING OPTIONS	11
7.2	DISPLAY AND SETTINGS	11
7.2.1	CHARGE LEVEL CHECK ON BATTERY	11
8	ERROR MESSAGES	12
8.1	BATTERY ERROR CODES	12
9	CLEANING AND SERVICING	13
9.1	BASIC CLEANING	13
9.1.1	CLEANING THE BATTERY	13
10	TROUBLESHOOTING, FAULT CLEARANCE AND REPAIR	14
10.1	TROUBLESHOOTING AND FAULT CLEARANCE	14
10.1.1	DRIVE SYSTEM OR DISPLAY DOES NOT START UP	14
10.1.2	ERRORS IN THE ASSISTANCE SYSTEM	14
10.2	REPAIR	15
10.2.1	ORIGINAL PART	15
10.2.2	REPLACING THE LIGHTS	15
10.2.3	ADJUSTING THE HEADLIGHT	15

11 RECYCLING AND DISPOSAL	16
11.1 DISPOSAL	16

1 PREFACE

Dear FIT customer,

The FIT system offers many useful functions and options and we are pleased that you have decided to choose our system.

Please read through the operating instructions carefully to ensure you use the system safely and get off to a quick start.

We hope you enjoy discovering the FIT's functions and have a fun ride every time you use it.

Thank you for placing your trust in FIT.

Your FIT Team

2 ABOUT THESE OPERATING INSTRUCTIONS

2.1 MANUFACTURER

Biketec GmbH
Luzernstrasse 84
CH-4950 Huttwil
fit-ebike.com/en-en/

2.2 LANGUAGE

The original operating instructions are written in German. A translation is invalid without the original operating instructions.

2.3 DECLARATION OF CONFORMITY

Biketec GmbH hereby declares that the products described in these operating instructions comply with EU directives. The complete EU Declaration of Conformity is available online at: fit-ebike.com/en-en/service/declaration/

2.4 ON INFORMATION

Different markings are used in the operating instructions to make them easier to read.

2.5 WARNINGS IN THESE OPERATING INSTRUCTIONS

Warnings indicate hazardous situations and actions. You will find the following warnings in the operating instructions:

**DANGER**

May lead to serious or even fatal injuries if ignored. Medium-risk hazard.

**CAUTION**

May lead to minor or moderate injuries if ignored. Low-risk hazard.

**NOTICE**

May lead to material damage if ignored.

3 SAFETY INSTRUCTIONS

3.1 GENERAL INFORMATION

Please read all safety instructions carefully. Failure to comply with the warnings or take residual risks into account may result in electric shock, fire and / or serious injury.

Keep the operating instructions in a safe place and have them readily available to consult. Pass these instructions on if you provide your e-bike for someone else's use.

The generic names used in these operating instructions, such as motor, battery and operating element, all refer to original FIT e-bike components.

3.2 RECHARGEABLE BATTERY

Remove the battery from the e-bike before you start working on the e-bike (e.g. inspection, repair, fitting, maintenance, work on the chain), transport it by car or plane or if you are not going to use it for extended period of time. There is a risk of injury if the e-bike system is activated unintentionally.

Do not open up the battery as you risk causing a short circuit.

Protect the battery from heat (e.g. including continuous direct sunlight), fire and being submerged in water. Do not store or operate the battery in close proximity to hot or flammable objects as this pose a risk of explosion.

Keep the unused battery away from paper clips, coins, keys, nails, screws or other metal objects which could cause an electrical arc between the contacts. A short circuit between the battery contacts can cause fire or burns.

Avoid any physical loads on the battery. They may inflict damage to the battery cells and cause flammable substances to leak out.

Do not put the charger and battery down next to flammable materials. Only charge batteries when they are dry and in a fireproof place. There is a risk of fire due to heat accumulating during charging.

The e-bike battery must not be left unattended while it is charging.

If the battery is used incorrectly, liquid may leak from it. Avoid coming into contact with the liquid. Rinse off with water in the event of accidental contact. If the liquid gets into eyes, seek medical attention. Leaked liquid can cause skin irritation and burns.

Vapours may be emitted if the battery is damaged or used improperly, ventilate with fresh air and consult a doctor if you suffer any pain or discomfort. The vapours can irritate the airways.

Charge the battery with original FIT chargers only. Risk of fire cannot be ruled out if non-original FIT chargers are used.

Use the battery in e-bikes with the FIT system only. This is the only way that the battery will be protected from dangerous overloading.

Only use original FIT rechargeable batteries which the manufacturer has approved for your e-bike. Using other batteries can result in injuries and risk of fire. FIT accepts no liability and offers no warranty if other batteries are used.

Keep the battery away from children.

Our e-bike rechargeable batteries are lithium-ion batteries which are developed and manufactured to the latest technical standards. Lithium-ion batteries have a high energy content when charged. In the event of a defect, possibly not visible on the outside, lithium-ion batteries may catch fire in very rare instances and under unfavourable conditions.

4 PRODUCT AND TECHNICAL SPECIFICATIONS

4.1 ULTRACORE FIT 48 V

Ultracore batteries were developed for integration into the down tube and are easy to fit and remove without tools. The batteries are perfectly matched to the FIT system and work safely and reliably. They cover a wide range of applications for short or long distances.

The intelligent battery management system protects the battery against overloading, overheating, overcurrent, undervoltage and other sources of error.

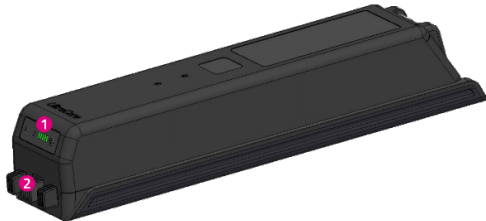

1. Battery level indicator
2. Charging socket

4.2 PROPER USE

All check lists and instructions for actions in these operating instructions met.

Only use original FIT rechargeable batteries which the manufacturer has approved for your e-bike.

The rechargeable batteries are designed to supply power to the e-bike motor only and must not be used for other purposes.

4.3 IMPROPER USE

Improper use refers to use which is not described under **proper use** or goes beyond **proper use**.

4.4 TECHNICAL DATA

4.4.1 ULTRACORE FIT 48

Rechargeable battery		Ultracore 720 FIT 48 V	Ultracore 960 FIT 48 V
Product code		500081	500256
Cell configuration		13S3P	13S4P
Capacity (nominal)	Ah	15	20
Energy (nominal)	Wh	720	960
Voltage (nominal)	V	48,1	48,1
Charging current (nominal)	A	4,8	4,8
Discharging temperature	°C	-20 to +55	-20 to +55
Charging temperature	°C	0 to +45	0 to +45
Storage temperature (recommended)	°C	10 to +25	10 to +25
Weight about	kg	3,7	4,7

5 TRANSPORTATION AND STORAGE

5.1 TRANSPORTATION



CAUTION

- Remove battery before transportation.
- There is a risk of injury if the drive system is switched on unintentionally.

5.1.1 TRANSPORTING E-BIKES

Never use bicycle racks which use the e-bike's handlebars or frame to hold the e-bike in an upside-down position. They can exert inadmissible forces on components during transportation. This can cause the supporting parts to break. The specialist dealer will advise you on how to select a suitable rack system properly and how to use it safely. Take the weight of the ready-to-use e-bike into account when transporting. Protect the electrical components and connections on the e-bike from the elements with suitable protective covers. Transport the battery in a dry, clean position where it is protected from direct sunlight.

5.1.2 TRANSPORTING THE BATTERY

Batteries are subject to hazardous goods regulations. Private individuals may transport undamaged batteries in road traffic. Commercial transport operators must comply with regulations on packaging, labelling and the transportation of hazardous goods. Open contacts must be covered and the battery securely packaged.

5.1.3 SHIPPING THE BATTERY

The battery is considered a hazardous good and only trained persons may pack and ship a battery. Contact your specialist dealer.

5.2 STORAGE



CAUTION

- Store e-bike, display, battery and charger in a clean, dry place where they are protected from sunlight.
- Do not store outdoors to ensure a long service life.
- The optimum storage temperature for your e-bike is between 10 °C and 20 °C.
- Temperatures under -10 °C or above +40 °C must generally be avoided.
- Store e-bike, display, battery and charger separately.

5.2.1 STORAGE MODE

The battery features a power-saving CHARGE TO STORAGE mode, which minimises discharge from the battery. Configure the CHARGE TO STORAGE mode in the battery settings.

5.3 BREAK IN OPERATION



NOTICE

- The battery discharges when not in use. This can cause irreparable damage to the battery.
- The battery must be recharged every 6 months.

The battery may become damaged if it is connected permanently to the charger. Never connect the battery to the charger permanently. If you remove the e-bike from service for longer than four weeks, you need to prepare it for a break in operation.

5.3.1 PREPARING FOR A BREAK IN OPERATION

- Remove battery from the e-bike.
- Charge battery to around 30–60% (storage mode).
- Before longer periods without use, it is recommendable to have your specialist dealer carry out an inspection and basic cleaning and apply preservative agent.

5.3.2 CARRYING OUT A BREAK IN OPERATION

Store the e-bike, battery and charger in a dry, clean environment. We recommend storing them in uninhabited rooms with smoke alarms. Dry locations with an ambient temperature between 10 °C and 20 °C are ideal. Check the battery level after 6 months. If only one battery level LED indicator lights up, recharge the battery to around 30–60%.

6 FITTING

6.1 FITTING THE BATTERY

6.1.1 REMOVING THE BATTERY

1. Turn safety lever to the right.

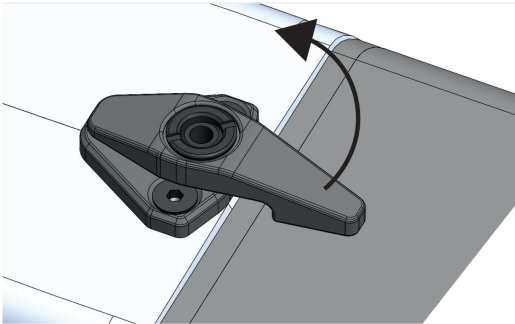

2. Push the battery up into the frame using your right hand.
⇒The lock hook in the frame is now released.
3. Support the battery from below with your right hand. Push the key towards the down tube.
⇒The lock hook releases the battery.
4. Depending on how much play the battery has in the down tube, the battery will fall out of the frame or can be pulled out of the down tube.
5. Remove the key from the lock.

6.1.2 INSERTING THE BATTERY

1. Use the contacts to place the battery in the lower holder.
2. Use the key to open the lock.
3. Push the key towards the down tube and hold it.
⇒The lock hook in the frame clears the way for the battery.
4. Tilt the battery into the down tube. Press the battery into the frame with some pressure.
5. Let go of the key.
6. The lock hook moves to the holding position and holds the battery.
7. Lock the lock. Remove the key.
8. Turn the safety lever to the left.

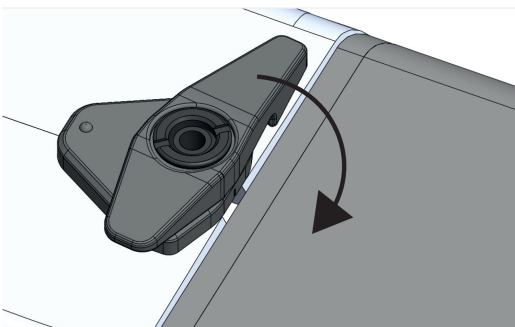

9. Check the battery for a secure fit.

7 OPERATION

7.1 CHARGING THE BATTERY

7.1.1 CHARGING OPTIONS

The battery can be charged while inserted in the e-bike or after it has been removed. Look in the e-bike manufacturer's original operating instructions to find where the e-bike charging socket is. Connect the charger to the e-bike charging socket (or directly to the battery) to charge. The charge indicator will automatically appear on the e-bike display screen if the battery is fitted into the e-bike. The display backlight will go out after a certain period of time. However, you can press the On-Off button to switch it back on again at any time.

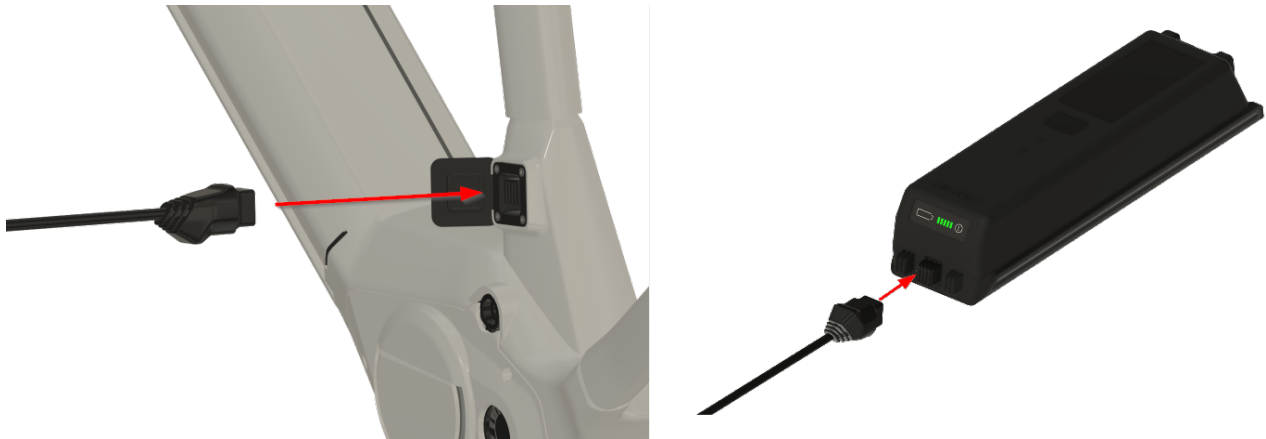

7.2 DISPLAY AND SETTINGS

7.2.1 CHARGE LEVEL CHECK ON BATTERY







1. Checking button for the battery charge level
Lights up the battery charge LEDs to check the remaining battery capacity or a possible fault with the battery itself.
2. Battery level LEDs
Indicate how much e-bike battery capacity is left. An error code is displayed in the event of a fault. You will find the error table later in these instructions.

Each lit battery level light represents around 20% of the battery capacity. If the battery is completely discharged, this is indicated by a rapidly flashing LED.

8 ERROR MESSAGES

8.1 BATTERY ERROR CODES

Flash sequence for the battery charge level LEDs after pressing the battery charge level button	Description	Action
 <p>LEDs go out briefly in sequence from right to left.</p>	<p>Permanent Error The battery has a permanent error</p>	<p>The battery needs to be replaced. Take your e-bike to your specialist dealer. The battery is considered to have an unknown defect in this state and must not be transported in a vehicle or by air. It is best if you contact your dealer.</p>
 <p>LEDs flash on briefly in sequence from right to left.</p>	<p>Charge Error The battery has been overcharged and the charger may have a fault</p>	<p>Take your e-bike to your specialist dealer.</p>
	<p>Current Error There may be a fault in the motor or charger, or the battery may have gone into deep discharge.</p>	<p>Take your e-bike to your specialist dealer.</p>
	<p>Temperature Error The battery temperature is outside the permitted range.</p>	<p>If flashing persists after the system has not been used for a long time, the battery needs replacing. Take your e-bike to your specialist dealer. The battery is considered to have an unknown defect in this state and must not be transported in a vehicle or by air. It is best if you contact your dealer.</p>
	<p>Authentication Error An authentication error may have occurred.</p>	<p>Check the connections for dirt. If the flashing still persists after cleaning the connections and after the battery has not been used for a while, take the e-bike to your specialist dealer.</p>

9 CLEANING AND SERVICING

9.1 BASIC CLEANING

9.1.1 CLEANING THE BATTERY



CAUTION

Risk of fire and explosion due to penetration by water

- The battery is only protected against simple spray water. Penetration by water can cause a short circuit.
- The battery may self-ignite and explode.
- Never clean the battery with a pressure washer, water jet or compressed air.
- Keep contacts dry and clean.
- Never immerse the battery in water.
- Never use cleaning agents.
- Remove the battery from the e-bike before cleaning.



NOTICE

- Never clean the battery with cleaning agents or with solvents, such as oil, thinners, alcohol or corrosion protection.
- Clean the battery electrical connections with a dry cloth or paintbrush only.
- Wipe off the decorative sides with a damp cloth.

10 TROUBLESHOOTING, FAULT CLEARANCE AND REPAIR

10.1 TROUBLESHOOTING AND FAULT CLEARANCE

10.1.1 DRIVE SYSTEM OR DISPLAY DOES NOT START UP

If the display and / or the drive system do not start up, proceed as follows:

1. Check if the battery is inserted correctly. If not, insert the battery correctly.
2. Start the drive system.
3. If the drive system does not start, remove the battery, check the charging status and charge if necessary.
4. Clean all contacts with a soft cloth.
5. Insert the battery.
6. Start the drive system.
7. If the drive system does not start, contact the specialist dealer.



NOTICE

If the battery terminal contacts are heavily soiled / oxidized. Take your e-bike to a specialist dealer for a detailed check.

10.1.2 ERRORS IN THE ASSISTANCE SYSTEM

Symptom	Cause	Remedy
Assistance is not available.	Is the speed too high?	1. Check display screen. The motor assistance is only active up to the maximum speed for which the e-bike is approved.
	Is the battery charged sufficiently?	2. Check battery is charged. 3. Recharge the battery if it is almost flat.
	The motor may become too hot during rides at high temperatures, up long inclines or when carrying a heavy load for a long time.	4. Switch off the drive system. 5. Wait a moment and then check again.
	The rechargeable battery, display or operating element may be connected incorrectly, or one or more of them may have a problem.	6. Contact your specialist dealer.
Assistance is not available.	Are the pedals being pushed?	1. Your e-bike is not a motorbike. Push the pedals.
	Is the system switched on?	2. Press on-off button (operating element) to switch on the system.
	Is the level of assistance set to OFF ?	3. Set the level of assistance to HIGH, STD, ECO or AUTO . 4. Contact your specialist dealer if you still feel that the no assistance is being supplied.

Symptom	Cause	Remedy
The assisted journey distance is too short.	The battery does not perform as well in winter weather.	This does not indicate a problem.
	The journey distance can be shorter depending on the road conditions, the level of assistance and the total light usage time.	1. Check battery is charged. 2. Recharge the battery if it is almost flat.
	Is the battery fully charged?	3. If the distance covered with a fully charged battery has become shorter, the battery may be affected. Replace the battery with a new one.
	The battery is a consumable. Repeated charging and long periods of use cause the battery to degrade (loss of power).	4. If the distance you can cover with one single charge is very short, replace the battery with a new one.
It is difficult to pedal.	Are the tires pumped to an adequate pressure?	1. Pump up tires.
	Is the level of assistance set to OFF ?	2. Set the level of assistance to HIGH, STD, ECO or AUTO .
	The battery charge might be low.	3. Check battery is charged. 4. Recharge the battery if it is almost flat.
	Have you switched on the system with your foot on the pedal?	5. Switch on the system again without applying pressure to the pedals. 6. If assistance is still not supplied, contact your specialist dealer.

10.2 REPAIR

Special expertise and tools are required for many repairs. That is why only a specialist dealer may perform repairs.

10.2.1 ORIGINAL PART

The individual e-bike parts have been carefully selected and matched to one other. Only original parts must be used for maintenance and repair. Observe the operating instructions for the new components.

10.2.2 REPLACING THE LIGHTS

Replace components with ones in the right power class.

10.2.3 ADJUSTING THE HEADLIGHT

The headlight must be positioned so that its beam hits the road surface 10 m in front of the e-bike.

11 RECYCLING AND DISPOSAL

11.1 DISPOSAL



Mechanical and electrical equipment, accessories and packaging should be recycled in an environmentally sound manner. Don't throw them in the garbage!



Only for EU countries: According to European Directives 2012/19/EU, 2006/66/EC and their transposition into national law, defective or unusable waste electrical and electronic equipment, rechargeable batteries and batteries must be collected separately and recycled in an environmentally sound manner.