



# HPR Range Extender V01 160 Wh



**User Manual**  
EN

# 1 Safety



These instruction contains information that you must observe for your personal safety and to prevent personal injury and damage to property. They are highlighted by warning triangles and shown below according to the degree of danger.

- ▶ Read the instructions completely before start-up and use. This will help you to avoid hazards and errors.
- ▶ Keep the manual for future reference. This user manual is an integral part of the product and must be handed over to third parties in case of resale.

## NOTE

Also observe the additional documentation for the other components of the HPR50 drive system as well as the documentation enclosed with the e-bike.

## 1.1 Hazard classification

### **DANGER**

The signal word indicates a danger with a **high** degree of risk which will result in death or serious injury if not avoided.

### **WARNING**

The signal word indicates a danger with a **medium** level of risk which will result in death or serious injury if not avoided.

### **CAUTION**

The signal word indicates a danger with a **low** level of risk which could result in a minor or moderate injury if not avoided.













## NOTE





A note in the sense of this instruction is important information about the product or the respective part of the instruction to which special attention is to be drawn.

## 1.2 IMPORTANT SAFETY INSTRUCTIONS





### WARNING

When using this product, basic precautions should always be followed, including the following:

-  Read all the instructions before using the product.
-  Do not put fingers or hands into the product.
-  The installation of the HPR Range Extender V01 may only be carried out by authorised dealers. The persons must be qualified accordingly, e. g. by training as a two-wheel mechatronics technician. They must be able to recognise possible dangers during installation. Otherwise, there is a risk that the Range Extender or other lithium-ion batteries on the e-bike will be damaged or that the Range Extender comes off during the ride due to incorrect mounting.
-  Liquid may leak from the Battery if used improperly. Avoid any contact with this liquid. Wash it off with water if you do come into contact with the liquid. Also seek medical attention if the liquid has come into contact with your eyes. Liquid leaking from the Range Extender can cause irritation or burns.
-  Never subject the Range Extender to mechanical shocks to prevent damage to the Range Extender.
-  To reduce the risk of injury, close supervision is necessary when the Range Extender is used near children.
-   Never open the Range Extender case or attempt to disassemble the Range Extender.  
WARNING – Risk of Fire – No User Serviceable Parts.
-  Do not use this product if the flexible power cord or output cable is frayed, has broken insulation, or any other signs of damage.
-  Never break or puncture the Range Extender.
-  Only charge the Range Extender in well ventilated rooms.
-  Only use the original TQ Charger (FSP235-14S4AC8C) to charge the Range Extender.
-  Use only original HPR Range Extenders to supply power to the drive system.

-  This equipment is not intended to be used at ambient temperatures less than -5 °C (23 °F) or above ambient temperatures of 40 °C (104 °F).
-  The Range Extender is intended to be charged when the ambient temperature is between 0 °C (32 °F) and 40 °C (104 °F). Never charge the Range Extender when ambient temperatures are outside this range.
-  Do not attempt to modify or repair the product. Check further detail in Chapter "1.3 Intended Use".
-  Only use this product within following temperature limits  
Operation: -5 °C to 40 °C / 23 °F to 104 °F  
Charging: 0 °C to 40 °C / 32 °F to 104 °F  
Storage: 0 °C to 40 °C / 32 °F to 104 °F  
Recommended storage: 10 °C to 20 °C / 50 °F to 68 °F

## 1.2.1 INSTRUCTIONS PERTAINING TO RISK OF FIRE

-  **Explosion and fire hazard with damaged Range Extender housing**
  - If the Range Extender housing is damaged, make sure to have it replaced by a TQ authorised bicycle dealer, even if the Range Extender is still functional.
  - Do not make any repair attempts under any circumstances.
-  **Explosion and fire hazard when short-circuiting the Range Extender terminals**
  - Keep the Range Extender away from metallic objects as there is a risk of short circuits. Do not allow nails, screws or other small, sharp and/or metallic objects to come into contact with the Range Extender (charging/discharging socket).
-  **Risk of explosion and fire in case of high heat, fire or contact with water**
  -  Protect the Range Extender from fire, high heat and also from extended direct exposure to sunlight.
  - Never immerse the Range Extender in water.

 **Danger of poisoning by gases from a smoking or burning Range Extender in case of damaged Range Extender or improper use.**

- Be careful not to breathe in the highly toxic gases from a smoking or burning Range Extender.
- Ensure good ventilation and consult a doctor if you notice any undesirable effects on the respiratory organs. The vapors may irritate the respiratory organs.

## 1.2.2 INSTRUCTIONS PERTAINING TO ELECTRIC SHOCK

 **The Electric risk and shock is only applicable for the TQ Charger (FSP235-14S4AC8C). Please check and read all safety instruction which are included in the Charger manual.**

# SAVE THESE INSTRUCTIONS

## 1.3 Intended Use

 The HPR Range Extender is intended exclusively for supplying power to the HPR50 drive system and must not be used for any other purpose.

Any other use or use that goes beyond this is considered improper and will result in the loss of the warranty. In case of non-intended use, TQ-Systems GmbH assumes no liability for any damage that may occur and no warranty for proper and functional operation of the product.

Intended use also includes observing these instructions and all the information contained therein as well as the information on intended use in the supplementary documents enclosed with the e-bike.

Faultless and safe operation of the product requires proper transport, storage, installation and operation.

## 2 Technical data

Nominal voltage	50.4 V
Nominal capacity	2.8 Ah
Nominal energy	160 Wh
Discharge logic	When operating the e-bike, the Range Extender is discharged first afterwards the battery.
Dimensions	Ø 76 mm, length 185 mm / Ø 3", length 7.3"
Charging temperature	0 °C to 40 °C / 32 °F to 104 °F
Operating temperature	-5 °C to 40 °C / 23 °F to 104 °F
Storage temperature	0 °C to 40 °C / 32 °F to 104 °F
Recommended storage temperature	10 °C to 20 °C / 50 °F to 68 °F
Weight	approx. 950 g / 2.1 lbs (without frame fastening like FIDLOCK®)
Rated Capacity	2.64 Ah
Capacity Fade	12.4 % after 400 charge-discharge cycles
Power	450 W
Power Fade	0 % after 400 charge-discharge cycles
Internal Resistance	0.29 Ω
Internal Resistance Increase	0.8 % after 400 charge-discharge cycles
Energy Round Trip Efficiency	96.3 %
Energy Round Trip Efficiency Fade	0 % after 400 charge-discharge cycles
Expected Lifetime in charge-discharge cycles	1002 charge-discharge cycles
Expected Lifetime in Years	10 years

Tab. 1: Technical data – HPR Range Extender V01

# 3 INSTALLATION INSTRUCTIONS

## 3.1 Installing the HPR Range Extender on the e-bike

The design of the mounting system for the HPR Range Extender on the e-bike depends on the manufacturer. This section shows how to mount the Range Extender on the down tube of the e-bike using the FIDLOCK® system.

Make sure especially in case of retrofit that no components of the e-bike such as the battery or wiring harness are damaged when installing the Range Extender.

Pay special attention to the following points:

- The assembly of the HPR Range Extender may only be carried out by authorised dealers. The personnel must be appropriately qualified, e.g. through training as a two-wheel mechatronics technician. They must be able to recognise possible dangers during assembly. Otherwise, there is a risk that the Range Extender or other lithium-ion batteries on the e-bike will be damaged or that the Range Extender comes loose during the ride due to insufficient fastening.
- Selection of the correct screw heads and screw lengths.
- Selection of the positions recommended by the bicycle manufacturer for the attachment.

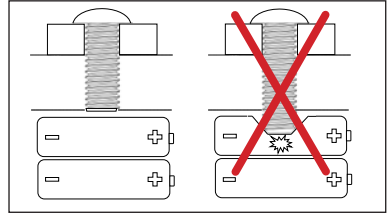

### 3.1.1 Fitting the FIDLOCK® Bike Base to the e-bike

#### WARNING

**Fire hazard due to damage to the battery inside the e-bike frame caused by using screws that are too long.**

- ▶ Only use the screws provided by the bicycle manufacturer or the ISO 7380-1 M5 × 10 A2 button head screws included in the scope of delivery to attach the FIDLOCK® Bike Base.

Using screws that are too long can damage the battery inside the e-bike frame.

## CAUTION

### Risk of accident due to release of the Range Extender from the locking mechanism

- ▶ Only use the screws provided by the bicycle manufacturer or the ISO 7380-1 M5 × 10 A2 button head screws included in the scope of delivery to attach the FIDLOCK® Bike Base.

Screws with a higher head mean that the FIDLOCK® Force Connector on the Range Extender is not firmly connected to the FIDLOCK® Bike Base and will come loose while riding.

- ▶ Fasten the FIDLOCK® Bike Base (Pos. 1 in Fig. 1) with the two button head screws (Pos. 2 in Fig. 1) in the threads provided for this purpose (Pos. 3 in Fig. 1, follow the specifications of the bicycle manufacturer) inside the e-bike frame.
- ▶ Tighten the two button head bolts with a torque of **2 Nm** or to the max. torque values specified by the bicycle manufacturer.

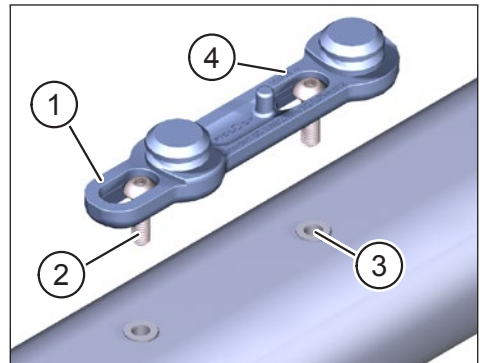

Fig. 1: Fasten the FIDLOCK® Bike Base to the e-bike

## NOTE

- ▶ Observe the inscription engraved "**upside >>**" when mounting on the FIDLOCK® Bike Base (Pos. 1 in Fig. 2). The upper edge of the FIDLOCK® logo (Pos. 2 in Fig. 2) on the FIDLOCK® Force Connector must point in the direction of the arrow from "**upside >>**".

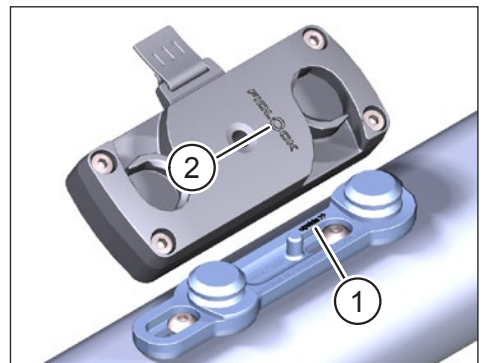

Fig. 2: Orientation of FIDLOCK® Bike Base and FIDLOCK® Force Connector



### 3.1.2 Fasten FIDLOCK® Force Connector to Range Extender

#### WARNING

**Fire hazard due to damage to the Range Extender by using screws that are too long**

- ▶ Only use the screws provided by the bicycle manufacturer or the ISO 4762 M4 × 16 A2 cylinder screws included in the scope of delivery to fasten the FIDLOCK® Force Connector.

Using screws that are too long can damage the battery in the Range Extender.

- ▶ Fasten the FIDLOCK® Force Connector (Pos. 1 in Fig. 3) in the threads (Pos. 3 in Fig. 3) in the Range Extender using the four M4 × 16 cylinder screws supplied (Pos. 2 in Fig. 3).
- ▶ Tighten the four cylinder screws with a torque of **1.0 Nm**.



Fig. 3: Fasten FIDLOCK® Force Connector to Range Extender

### 3.1.3 Insert and lock the Range Extender on the FIDLOCK® Bike Base

- ▶ Place the Range Extender (Pos. 1 in Fig. 4) with the fastened FIDLOCK® Force Connector (Pos. 2 in Fig. 4) diagonally onto the FIDLOCK® Bike Base (Pos. 3 in Fig. 4). The pin (Pos. 4 in Fig. 4) on the FIDLOCK® Bike Base must slide into the corresponding socket in the FIDLOCK® Force Connector when it is put on. The magnets support the attachment and the Range Extender should automatically lock into place with an audible click.

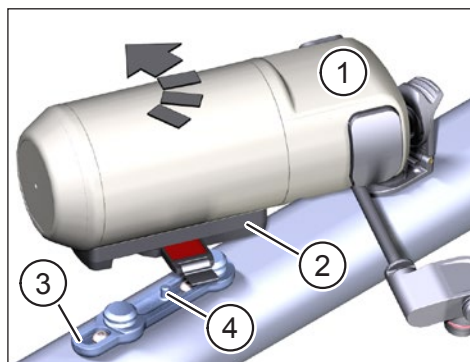

Fig. 4: Insert Range Extender

### 3.1.4 Locking the Range Extender into the FIDLOCK® Bike Base

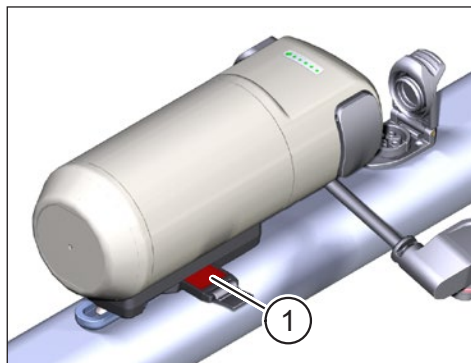

Fig. 5: FIDLOCK® system unlocked

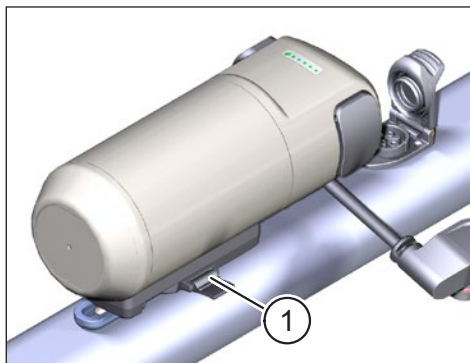

Fig. 6: FIDLOCK® system locked

The FIDLOCK® system is still unlocked after inserting the Range Extender. This condition is indicated by the red field (Pos. 1 in Fig. 5) on the locking tab.

- ▶ Push the locking tab in as far as it will go (see Pos. 1 in Fig. 6), to fix the Range Extender firmly in place.

#### **⚠ CAUTION**

##### **Risk of accident due to unlocked Range Extender**

- ▶ Always lock the Range Extender with the locking tab in the FIDLOCK® system before go riding.

Otherwise there is a risk that the Range Extender will come loose while riding, which can lead to a crash.

#### **NOTE**

- ▶ Check the FIDLOCK® Bike Base and the FIDLOCK® Force Connector for dirt and damage before every ride.

For more information on the FIDLOCK® TWIST system and compatible accessories, please visit <http://www.fidlock-bike.com/TQ>.

### 3.1.5 Connect the connection cable to the Range Extender

- ▶ Connect the plug (Pos. 1 in Fig. 7) of the connection cable to the socket (Pos. 2 in Fig. 7) in the Range Extender.
- ▶ Fasten the connector to the Range Extender with the M3 × 8 socket head screw (Pos. 3 in Fig. 7) included in the scope of delivery of the cable, with a torque of 1 Nm. Never use a longer screw. Otherwise there is a risk of damaging the electronics in the Range Extender.

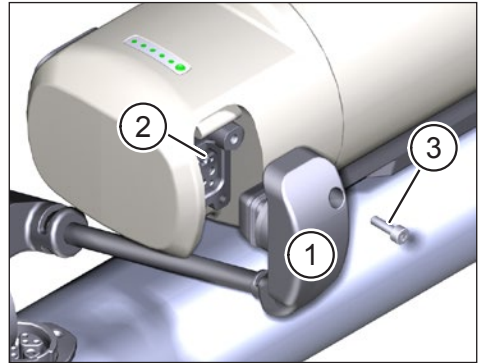

Fig. 7: Fasten the connection cable to the Range Extender

#### NOTE

Connecting cables are available in various versions with different cable lengths and connector orientations to meet the requirements of the respective installation situation.

- ▶ Enquire at the e-bike manufacturer about the connection cable you need.

### 3.1.6 Connect the connection cable to the charging port of the e-bike

- ▶ Unfold the cover (Pos. 1 in Fig. 8) of the charging port (Pos. 2 in Fig. 8) on the e-bike frame.
- ▶ Check that the terminals in the charging port are free of dirt and clean them if necessary.
- ▶ Align the connector (Pos. 3 in Fig. 8) of the connection cable so that the connector coding of the plug and charging port match.
- ▶ Insert the plug into the charging port and secure the plug with the cover (Pos. 1 in Fig. 8).

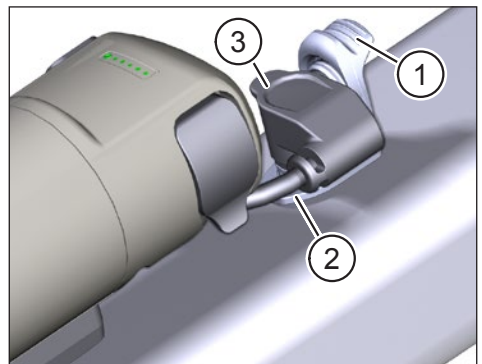

Fig. 8: Connect the connection cable to the charging port

## CAUTION

### **Risk of accident due to free hanging connection cable on the Range Extender**

- ▶ Always connect the Range Extender to the charging port of the battery in the bicycle frame when you have installed the Range Extender on the bicycle.

Otherwise there is a risk that the free hanging connection cable on the Range Extender will get caught in the pedals while riding and so leads to crash.

## 4 OPERATION

### 4.1 Range Extender charging

## DANGER

- ▶ Only use TQ Charger (FSP235-14S4AC8C) for charging the Range Extender.

## WARNING

### **Fire or electric shock hazard due to damage to battery, Range Extender, charger, cable and plug.**

- ▶ Never charge the Range Extender if you notice any damage to the Battery, Range Extender, Charger, cables or connectors.
- ▶ Only perform the charging process in a place where there are no flammable materials in surrounding.
- ▶ Never leave the charging process unattended.
- ▶ Do not attempt to modify or repair the product. Check further detail in Chapter "1.3 Intended Use".
- ▶ Only use this product within following temperature limits:  
Operation: -5 °C to 40 °C / 23 °F to 104 °F  
Charging: 0 °C to 40 °C / 32 °F to 104 °F  
Storage: 0 °C to 40 °C / 32 °F to 104 °F  
Recommended storage: 10 °C to 20 °C / 50 °F to 68 °F
- ▶ Further safety warnings regarding Risk of Fire, Electric Shock or Injury to persons can be found in the section: "1.2 Important Safety Instructions".

## NOTE

- The drive system detects whether the Range Extender is connected to the charging port of the battery in the bicycle frame. In this case the drive system is deactivated during the charging process for safety reasons.
- The charging system detects whether the Range Extender is connected to the charging port of the battery in the bicycle frame. In this case both are charged, first the battery and afterwards the Range Extender.

## ⚠ CAUTION

### Risk of accident due to activated drive system during the charging process

- ▶ Always connect the Range Extender to the charging port of the battery in the bicycle frame when you have installed the Range Extender on the bicycle.

This is the only way to ensure that the drive system is deactivated during charging. Otherwise there is a risk that you can start the drive system during charging and that the plugged-in charging cable will cause damage or leads to a crash.

- ▶ Connect the charger to the power supply.

- ▶ Unfold the cover (Pos. 1 in Fig. 9) on the charging port of the Range Extender.

- ▶ Check that the terminals in the charging port (Pos. 2 in Fig. 9) are free of dirt and clean them if necessary.

- ▶ Insert the charging plug (Pos. 3 in Fig. 9) of the charger into the charging port of the Range Extender.

- ▶ Pull the charger plug of the charger out of the charging port of the Range Extender when charging is complete.

- ▶ Close the cover on the charging port when charging is complete.

- ▶ Disconnect the charger from the power supply.

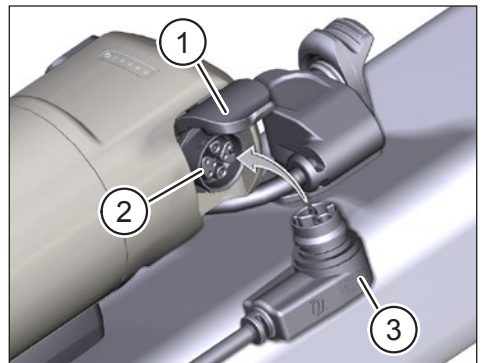

Fig. 9: Range Extender charging

## 4.3 Notes on Charging

### NOTE

The temperature of the Range Extender must be within the permissible charging temperature range (0 °C to 40 °C / 32 °F to 104 °F). Otherwise the charging process will not start.

- The Range Extender can be charged directly on the e-bike or separately.
- The drive system is deactivated during charging when the Range Extender is connected to the battery charging port in the bicycle frame.
- The charging status of the Range Extender can be read on the display and on the 5 LEDs on the side of the Range Extender. Briefly cover the light sensor to the left of the LEDs with a finger to activate this display.
- New Range Extenders have a state of charge of 20 % to 30 % due to transport regulations and must be recharged within less than 6 months after manufacturing.
- The Range Extender should be recharged immediately after it has been completely discharged (state of charge <5 %).
- 1 charge cycle can consist of a full charge of the Range Extender capacity (0 % to 100 %) or several partial charges that add up to 100 % of the charge capacity.
- The Range Extender capacity should be at least 60 % after 500 charging cycles.

## 5 TRANSPORT AND STORAGE

- The transport of lithium batteries is subject to country-specific laws and regulations. Inform yourself about the respective regional regulations and observe them during transport.
- For transport observe the special requirements for packaging and labeling that apply in your country.
- Contact a TQ authorised bicycle dealer for information on transporting the Range Extender and suitable transport packaging. For transport outside the bicycle frame, we recommend a certified transport box.
- It's recommended to store the Range Extender at room temperature (approx. 10 °C to 20 °C / 50 °F to 68 °F) and do not expose it to direct sunlight.
- Do not store the Range Extender near heat sources or other easily flammable materials.
- Store the Range Extender in dry rooms (humidity below 70 %) and protect it from rain and moisture.
- Store the Range Extender only in rooms equipped with smoke detectors.
- Charge the Range Extender to approx. 30 % to 60 % before storage.
- Check the Range Extender every 6 months and recharge it to approx. 30 % to 60 %.
- Fully charge the Range Extender before use.
- Do not store the Range Extender with the charger plugged in.

## 6 USER MAINTENANCE

### 6.1 Maintenance and Service

All service, repair or maintenance work performed by a TQ authorized bicycle dealer. Your bicycle dealer can also help you with questions about bicycle use, service, repair or maintenance.

### 6.2 Cleaning

- Never immerse the Range Extender in water to clean it.
- Never clean the Range Extender with a water jet.
- Only clean the Range Extender with a soft, damp cloth.
- Please contact a TQ authorised bicycle dealer, if the Range Extender is no longer functional.

## 7 Environmentally friendly disposal

The components of the drive system and the batteries must not be disposed of in the residual waste garbage can.

- Dispose of metal and plastic components in accordance with country-specific regulations.
- Dispose of electrical components in accordance with country-specific regulations. In EU countries, for example, observe the national implementations of the Waste Electrical and Electronic Equipment Directive 2012/19/EU (WEEE).
- Dispose of batteries and rechargeable batteries in accordance with the country-specific regulations. In EU countries, for example, observe the national implementations of the Waste Battery Directive 2006/66/EC in conjunction with Directives 2008/68/EC and (EU) 2020/1833.
- Observe additionally the regulations and laws of your country for disposal.

In addition you can return components of the drive system that are no longer required to a bicycle dealer authorized by TQ.





## 8 BMS Reset

If you want to reset the software of the battery management system for the purpose of re-use, preparation, repurposing or remanufacturing according to article 14 of REGULATION (EU) 2023/1542, please contact TQ-Systems GmbH via the following e-mail address: [ebike@tq-group.com](mailto:ebike@tq-group.com)



## NOTE

For more information and TQ product manuals in various language, please visit [www.tq-ebike.com/en/support/manuals](http://www.tq-ebike.com/en/support/manuals) or scan this QR-Code.



We have checked the contents of this publication for conformity with the product described. However, deviations cannot be ruled out so that we cannot accept any liability for complete conformity and correctness.

The information in this publication is reviewed regularly and any necessary corrections are included in subsequent editions.

All trademarks mentioned in this manual are the property of their respective owners.

Copyright © TQ-Systems GmbH