



# **MOUNTAINBIKE**

**User Manual**



WITH THIS SIMPLON BIKE YOU HAVE PURCHASED A HIGH QUALITY PRODUCT.

In this user manual you will find all the important information for safe and damage-free assembly, use and maintenance of your new bike. If you have any doubts or uncertainties about the work on your bike, be sure to consult your dealer.

This user manual must be read and understood before using your bike for the first time. Make sure that third party users are also informed about the contents of this user manual and understand and observe the contents.

Keep this user manual for future reference. If you sell or give away your bike, this user manual must be included with your bike.

This user manual is additionally available as a PDF file at [simplon.com](http://simplon.com).

Proper maintenance and care of your bike is important, as only this will allow a long, trouble-free operation, optimum performance and appropriate riding safety (see „7. Maintenance“ on page 23).

Due to the variety of models and components, this user manual may contain information that does not apply to your bike. Pictures and illustrations may differ from the actual products used. If different variants are described, this is clearly indicated.

Please take the time to read this user manual carefully. However, despite the user manual, you can not and should not immediately try to do all the necessary work yourself. Your SIMPLON dealer has the necessary tools and knowledge to keep your new bike "in good shape" for a long time.

Have fun with your new SIMPLON bike!

Your SIMPLON Fahrrad GmbH

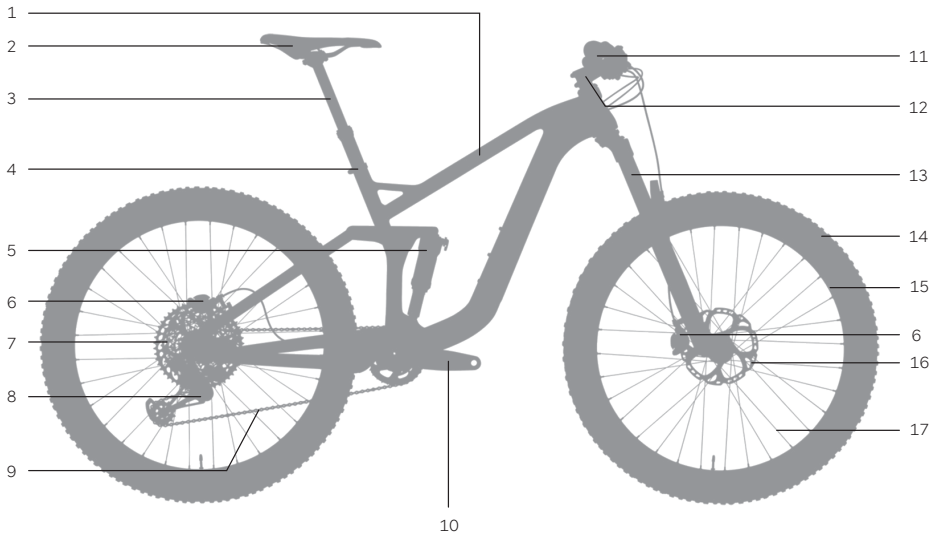

- 1 Frame
- 2 Saddle
- 3 Seat post
- 4 Seat post clamp
- 5 Shock
- 6 Brake caliper
- 7 Cassette
- 8 Rear derailleur
- 9 Chain

- 10 Crank
- 11 Handlebar with control elements
- 12 Stem
- 13 Fork
- 14 Tires
- 15 Rim
- 16 Brake disc
- 17 Spoke

<b>1. GENERAL .....</b>	<b>5</b>
1.1 Explanation of safety instructions used.....	5
1.2 Target group.....	5
1.3 Additional information from the component manufacturers.....	5
1.4 Tools.....	5
1.5 Mounting of trailers, child seats and luggage racks.....	5
1.6 Wear parts.....	6
1.7 Maximum system weight / intended use .....	6
1.8 Disclaimer .....	6
1.9 Guarantee / Crash Replacement .....	6
<b>2. SAFETY .....</b>	<b>7</b>
2.1 General safety .....	7
2.2 Safety in handling the brakes .....	8
2.3 Safety when using a luggage rack.....	8
2.4 Duty of care of the rider .....	8
2.5 Safety on public roads.....	9
<b>3. ASSEMBLING THE BIKE .....</b>	<b>11</b>
3.1 Open the bike box and remove contents (only for shipping).....	11
3.2 Straightening the handlebar and adjust headset play.....	12
3.3 Adjusting the inclination of the handlebar .....	13
3.4 Adjusting the saddle height .....	14
3.5 Attaching the pedals.....	16
<b>4. BEFORE THE FIRST RIDE.....</b>	<b>17</b>
<b>5. ACTIVITIES BEFORE AND AFTER THE RIDE .....</b>	<b>18</b>
5.1 Before the ride .....	18
5.2 After the ride.....	20
5.3 After a crash.....	21
<b>6. TRANSPORT, STORAGE AND DISPOSAL .....</b>	<b>22</b>
6.1 Transport by car.....	22
6.2 Storage of the bike.....	22
6.3 Shipping the bike.....	22
<b>7. MAINTENANCE .....</b>	<b>23</b>
7.1 Torques.....	25
7.2 Tire pressure .....	26

# 1. GENERAL

## 1.1 EXPLANATION OF SAFETY INSTRUCTIONS USED



### **DANGER**

...indicates a hazard with a high degree of risk that will result in death or serious injury if not avoided.



### **WARNING**

...indicates a hazard with a medium degree of risk, which can result in minor or moderate injuries if not avoided.



### **CAUTION**

...indicates a hazard with a low degree of risk that may result in minor or moderate injury if not avoided.

## 1.2 TARGET GROUP

The target group of this user manual is you, the owner of the SIMPLON bike. If you intend to perform work on your bike yourself, basic knowledge of bicycle technology is an important prerequisite. If you have any questions or doubts, be sure to consult your dealer. Incorrect assembly or incorrect maintenance of your bike can lead to serious accidents with fatal consequences!

## 1.3 ADDITIONAL INFORMATION FROM THE COMPONENT MANUFACTURERS

All important information for the various life cycles has been integrated into this user manual. If you are interested in more detailed component-specific information, you can refer to the assembly instructions and product information provided by the component manufacturers.

## 1.4 TOOLS

All work on the bicycle may only be carried out with suitable tools. All screw connections must be tightened with a suitable torque wrench. Faultless assembly or disassembly of the components can only be guaranteed if the tools are in perfect working order and undamaged.

## 1.5 MOUNTING OF TRAILERS, CHILD SEATS AND LUGGAGE RACKS

Trailers may only be attached with special mounts. Special adapters are available for many SIMPLON bike models. Before using a trailer, find out if an adapter is available for your bike model. Further information on the maximum weight of the trailer can be found in the Intended use at [simplon.com](http://simplon.com) or by scanning the adjacent QR code:



Child seats must not be mounted on the seat post or the luggage rack. The mounting of child seats on the seat tube is only allowed on aluminum frames.

Luggage racks may only be mounted if attachment points are available. The maximum load for retrofitted luggage racks is 25 kg. The maximum system weight (see „1.7 Maximum system weight / intended use“ on page 6) must not be exceeded by loading the rack!

The assembly of further add-on parts may only be carried out after consultation with SIMPLON.

## 1.6 WEAR PARTS

The bicycle as a technical product consists of many components that are subject to wear due to their function. The components mentioned in the following list should therefore be checked regularly and replaced by a dealer as required:

- Tires and tubes
- Rims
- Brake discs / brake pads
- Bearings (headset, bottom bracket, rear triangle bearings, hub bearings)
- Chains, cassettes and sprockets
- Handlebar and stem
- Grips
- Saddle and seat post
- Grease, lubricant, hydraulic oil and brake fluid
- Inner and outer cables for brakes and gears
- Suspension fork / shock
- Stickers and coating

## 1.7 MAXIMUM SYSTEM WEIGHT / INTENDED USE



### **DANGER**

#### **RISK OF ACCIDENT IF THE MAXIMUM SYSTEM WEIGHT IS EXCEEDED OR THE INTENDED USE IS DISREGARDED!**

Exceeding the maximum system weight or use outside the intended use can weaken components and result in sudden and uncontrolled component failure.

- You can find the maximum system weight and the intended use of your bike at [simplon.com](https://simplon.com) or by scanning the adjacent QR code.
- The maximum system weight must not be exceeded and the intended use must not be disregarded!
- If components are replaced, their maximum system weight and category of use must not be less than that of the bicycle.



## 1.8 DISCLAIMER

The activities listed in this manual must be performed by persons with sufficient expertise.

The user is liable for damages as a result of:

- Use outside the intended use
- Non-compliance with safety-relevant regulations
- Improper assembly, repair and maintenance
- Use of non-approved spare parts and accessories
- Change in the state of construction
- Tuning

## 1.9 GUARANTEE / CRASH REPLACEMENT

All information about warranty and crash replacement can be found at <https://www.simplon.com>

## 2. SAFETY

### 2.1 GENERAL SAFETY



#### **DANGER**

##### **RISK OF INJURY DUE TO INSUFFICIENT SAFETY EQUIPMENT!**

Effective safety equipment makes a valuable contribution to personal safety.

- Wear a helmet every time you ride.
- Always wear high visibility and reflective clothing.



#### **DANGER**

##### **DANGER OF ACCIDENT DUE TO MISJUDGEMENT OF OTHER ROAD USERS!**

The speed of cyclists is usually underestimated by other road users.

- Always ride with foresight and do not rely on other road users to react appropriately.



#### **DANGER**

##### **RISK OF ACCIDENT DUE TO SUDDEN FAILURE OF PRE-DAMAGED OR WORN COMPONENTS!**

Bicycles are exposed to very high loads and high wear. In addition, crashes or unplanned riding maneuvers cause unpredictable load peaks. These loads can damage components of your bike without notice.

- Your bike must be checked regularly by your dealer for wear and damage. See also „7. Maintenance“ on page 23.
- Worn or damaged components must be replaced.



#### **DANGER**

##### **DANGER OF ACCIDENT DUE TO UNREPAIRED HEADSET PLAY!**

In the event of headset play over a longer period of time, the headset can create a notch effect on the steerer tube. As a result of this notch effect, the steerer tube can break, which can cause crashes with serious consequences!

- Regularly check and correct headset play (see „3.2 Straightening the handlebar and adjust headset play“ on page 12).
- If anything is unclear, consult your dealer.



#### **DANGER**

##### **RISK OF ACCIDENT DUE TO CONTACT BETWEEN FOOT AND FRONT WHEEL OR MUDGUARD!**

Depending on the frame size, shoe size and foot position on the pedal, the tip of the foot may touch the front wheel or the mudguard if the steering angle is large.

- When riding slowly, be aware that the steering angle may be restricted.
- This is not a problem when riding faster, as the steering angle is usually smaller here.

## 2.2 SAFETY IN HANDLING THE BRAKES



### **DANGER**

#### **DANGER OF ACCIDENT DUE TO REDUCED BRAKING POWER AS A RESULT OF BRAKE PADS NOT BEING BRAKED IN!**

Disc brakes can only develop their full braking power after careful braking in the brake pads. To do this, choose a road away from public traffic.

- Brake 20 to 30 times with the front or rear brake from 30 km/h to 5 km/h and then repeat the process for the second brake. Braking should be as hard as possible without skidding.



### **DANGER**

#### **DANGER OF ACCIDENT DUE TO HIGH BRAKING FORCE OF THE DISC BRAKES!**

Modern disc brakes have a very high braking force. Sudden braking can lead to loss of control of the bicycle.

- Familiarize yourself with the braking effect of the disc brakes away from public traffic in a safe environment.

## 2.3 SAFETY WHEN USING A LUGGAGE RACK



### **WARNING**

#### **RISK OF ACCIDENT DUE TO INCORRECT HANDLING OF THE LUGGAGE RACK!**

Incorrect handling of the luggage rack or the luggage attached to it can lead to serious accidents while riding.

- Luggage racks may only be loaded with the prescribed maximum load. You will find information on the maximum load on the luggage rack.
- The weight limit of the bicycle (see „1.7 Maximum system weight / intended use“ on page 6) must not be exceeded even with a loaded rack.
- The handling of the bicycle, especially the steering and braking behavior, can change due to the loaded rack.
- Further equipment of the luggage rack (panniers, etc.) must be attached according to the specifications of the respective manufacturer.
- Luggage must be placed in such a way that the visibility of the light and reflectors is not impaired.
- Luggage must be evenly distributed on both sides of the rack.
- Luggage must be secured against falling or slipping. There must be no loose parts hanging down.
- Fastening elements of the luggage rack must be secured and checked regularly.
- Luggage racks must not be changed or modified.
- No trailers may be attached to the luggage rack.

## 2.4 DUTY OF CARE OF THE RIDER

The use of this manual does not release the rider from the duty of care to keep the bicycle in safe operating condition. In case of doubt, SIMPLON service or your specialist dealer must be consulted.



## 2.5 SAFETY ON PUBLIC ROADS



### DANGER

#### DANGER DUE TO INSUFFICIENT EQUIPMENT FOR PUBLIC ROAD TRAFFIC!

Not all SIMPLON bikes are intended for use on public roads. If your bike is to be used in public road traffic, the required equipment (lights and reflectors) must be retrofitted by your dealer.

### AUSTRIA

In Austria, the necessary equipment for public road traffic is regulated in the "Fahrradverordnung". If you want to ride your bike on public roads in Austria, the following equipment must be fitted:

Description	Special notes
Front light and rear light	White or bright yellow light on the front, must illuminate the road ahead, red (possibly also flashing) rear light Front and rear lights must be fitted during twilight, darkness or when visibility conditions otherwise require it.
Reflectors front and rear	front: white, rear: red, min. 20 cm <sup>2</sup> light entry area must comply with ECE regulation no. R 104, may be connected to the front light.
Reflectors on the side	white or yellow reflective tires (continuous ring) or spoke reflectors, yellow or white, min. 20 cm <sup>2</sup> light entry area and comply with ECE regulation no. R 104 or other lateral reflective devices that are equivalent.
Pedal reflector	no size indications, reflectors on the shoes or on the pedal cranks or pedals

Reflectors must always be in place regardless of visibility.

### GERMANY

In Germany, the necessary equipment for public road traffic is regulated in the "Straßenverkehrs-Zulassungs-Ordnung" (StVZO).

If you want to ride your bike on public roads in Germany, the following equipment must be fitted:

Description	Special notes:
White front light and white reflector	Front and rear lights as well as the reflectors must be fitted during twilight, darkness or when visibility conditions otherwise require it. The lights as well as the reflectors must be firmly attached during operation and secured against unintentional adjustment under normal operating conditions and must be ready for use at all times. The front light must be adjusted so that other road users are not dazzled.
Red tail light and red reflector	
Pedal reflector	Both pedals must have forward and rearward acting yellow reflectors.
Spoke reflector	Two spoke reflectors each must be fitted to the front and rear wheel. Alternative: Tires with reflective stripes or one spoke stick per spoke.

Different legal requirements may apply outside Germany.

## SWITZERLAND

In Switzerland, the necessary equipment for public road traffic is regulated in the "Verordnung über die technischen Anforderungen an Straßenfahrzeuge" (VTS).

If you want to ride your bike on public roads in Switzerland, the following equipment must be fitted:

Description	Special notes:
White or bright yellow front light	Front and rear lights and reflectors must be firmly attached to the bicycle.
Red tail light and red reflector	The front and rear lights must always be switched on when visibility conditions require it and must be visible for 100 m in good weather conditions. The front and rear lights must not dazzle other road users and must not flash. The front light must be adjusted so that other road users are not dazzled. A rear-facing red reflector with an illuminated area of at least 10 cm <sup>2</sup> must be permanently attached. This must be visible at night in good weather at 100 m in the light of a motor vehicle high beam.
Pedal reflector	The pedals must have front and rear reflectors with an illuminated area of at least 5 cm <sup>2</sup> . This excludes racing pedals, safety pedals and similar.

### 3. ASSEMBLING THE BIKE

Normally, the bike is assembled to a roadworthy condition by your dealer. However, if the bike was sent to you in a shipping box (possibly after repairs by SIMPLON or your dealer), below you will find a few simple steps to get your bike in running condition.



#### **DANGER**

#### **RISK OF ACCIDENT DUE TO IMPROPERLY MOUNTED COMPONENTS!**

Improperly mounted components can come loose while riding!

- The assembly must be carried out in accordance with this user manual.
- In case of doubt, SIMPLON Service or your specialist dealer must be consulted.

#### **REQUIRED TOOLS**

For the assembly of the bike you need the following tools depending on the model and equipment variant:

- 4 mm, 5 mm, 6 mm, 8 mm hex key
- Torx T25
- Torque wrench with 4 mm, 5 mm, 6 mm and 8 mm hexagon socket and Torx T25 insert
- 15 mm open-end wrench

#### **3.1 OPEN THE BIKE BOX AND REMOVE CONTENTS (ONLY FOR SHIPPING)**

Inspect the bike box for external damage before opening and then inspect the contents for completeness! Please report any defects immediately!

Carefully open the bike box by one of the narrow side panels. When opening the bike box with a knife, be careful not to damage internal parts.

### 3.2 STRAIGHTENING THE HANDLEBAR AND ADJUST HEADSET PLAY



#### CAUTION

The screw for adjusting the headset play (1) is not used for tightening the stem, but only for adjusting the bearing play!

1. Loosen the clamping screw(s) (2) of the stem with a hex key. Do not loosen the screw for adjusting the headset play (1).
2. Turn the handlebar in riding direction and align the handlebar with the front wheel.

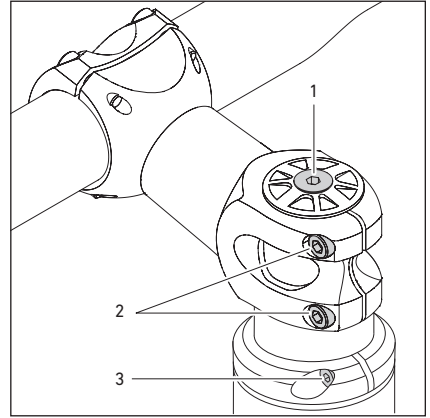

3. Check the headset play: Pull the front brake and slowly move the bike back and forth.  
→ No play should be noticeable.
4. If headset play is noticeable:
  - 4.1 When using an optional headset with steering stop: Loosen the screw (3) of the steering stop.
  - 4.2 Turn the headset play adjustment screw (1) clockwise a quarter turn.
5. Check the headset play and repeat the previous steps as necessary until there is no headset play.
6. If present, tighten the screw of the steering stop (3) with a torque of 4.5 Nm.
7. Tighten the clamping screw(s) (2) of the stem alternately.  
You can find the necessary tightening torque on the stem .
8. In case of doubt or ambiguity, the help of your dealer must be sought.

### 3.3 ADJUSTING THE INCLINATION OF THE HANDLEBAR

The ends of the handlebar are usually angled. Adjust the handlebar so that the wrists are not bent too much.

1. Turn the handlebar clamp screws counterclockwise until you can adjust the inclination of the handlebars.

2. Check if there is a protective film between the handlebar and stem.

If a protective film is present:

2.1 Completely unscrew the handlebar clamp screws and remove the handlebar clamp(s).

2.2 Take off the handlebar and remove the protective film from the handlebar.

2.3 Apply assembly paste to the clamping surface of the handlebar.

2.4 Reattach the handlebar and the handlebar clamp(s).

2.5 Turn the clamp screws clockwise and tighten them so that the handlebar can still be moved.

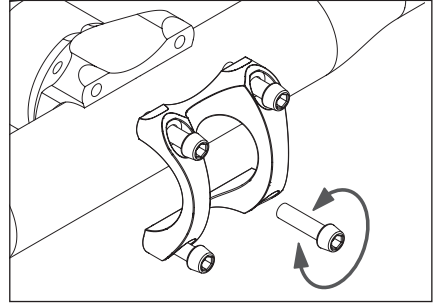

3. Center the handlebar and adjust the inclination of the handlebar.

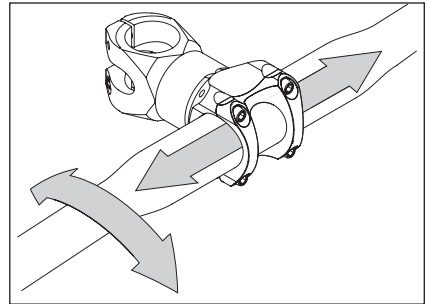

4. Tighten the handlebar clamp screws alternately in small increments until the tightening torque is reached.

You can find the necessary tightening torque on the stem.

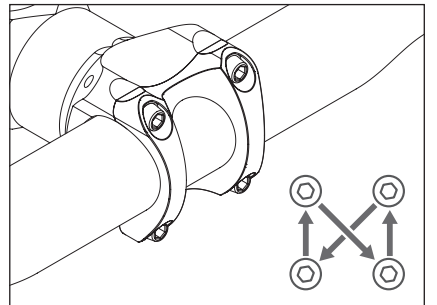

After adjusting the inclination of the handlebar, the brake and shift levers must be returned to the correct position.

### 3.4 ADJUSTING THE SADDLE HEIGHT



#### **DANGER**

#### **RISK OF ACCIDENT AND DAMAGE IF THE MINIMUM INSERTION DEPTH OF THE SEAT POST IS NOT REACHED!**

If the minimum insertion depth is not reached, the seat post may break during riding or the frame may be damaged.

- The minimum insertion depth marked on the seat post must not be undercut under any circumstances.

The correct seat height is determined by the pedaling action. The leg must not be maximally extended during the normal pedaling motion in the lowest position of the pedal crank, the furthest distance of the pedal from the saddle. If the seat height is too high, it is difficult to overcome this lowest point, the step becomes out of round. A too low sitting position puts strain on the knee joint, a too high sitting position puts strain on the hip joint.

The saddle height is optimally adjusted when the leg is fully extended, while the heel is on the pedal and is in the lowest position (shoes with flat soles, or flat heels must be used!). The hips must remain straight.

1. Open the bolt(s) of the seat post clamp.
2. Change the height of the saddle by pulling out or pushing in the seat post and straighten the saddle.

The minimum insertion depth is marked on the seat post. The marking must not be visible after adjusting the seat height!

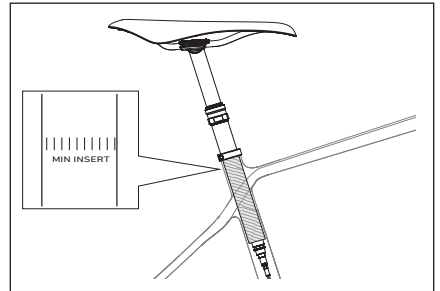

3. Tighten the bolt(s) of the seat post clamp to the required torque.  
You will find the required tightening torque on the clamp.

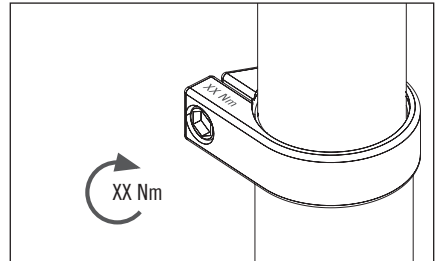

4. If the seat post is secured with a clamp with quick-release lever instead of the bolted clamp, adjustment is made by opening and closing the quick-release lever. Tighten the quick-release only "hand-tight" and with feeling. If the seat post is not tight enough, open the quick-release lever again, tighten the nut on the opposite side slightly and close the lever. Repeat this process until the seat post is firmly seated.
5. Sit on the bike and check the correct height of the saddle.
  - Safe getting on and off the bicycle is possible.
  - When standing, the foot should just be able to reach the ground.

## DROPPER SEAT POST



### NOTE

#### **RISK OF DAMAGE TO THE SEAT POST IF THE SEAT HEIGHT IS NOT ADJUSTED PROPERLY!**

If a dropper seat post with internal cable routing is pushed into the frame without pulling the cable, the cable kinks. Leaks and malfunctions are the result.



### REDUCING THE SEAT HEIGHT

1. Open the saddle clamp.
2. Carefully push in the seat post and at the same time carefully pull the cable out of the opening in the seat tube of the frame.
3. Lay the cable free of tension and kinks.
4. Close the saddle clamp.

### RAISING THE SEAT HEIGHT

1. Open the saddle clamp.
2. Carefully pull out the seat post and at the same time carefully push the cable.  
→ Note the minimum insertion depth of the dropper seat post!
3. Lay the cable free of tension and kinks.
4. Close the saddle clamp.
  - When using a screwed clamp, you will find the required tightening torque on the clamp.
  - When using a clamp with quick-release lever, the lever must be closed as tightly as possible by hand.

### 3.5 ATTACHING THE PEDALS

One of the pedals has a right-hand thread and the other a left-hand thread.

Most pedals are marked with "L" and "R" for the mounting side. On some pedals, the left pedal is marked with a groove on the axle.

Further details can be found in the manufacturer's manual.

1. Check whether washers are included in the scope of delivery. If present, place both washers on both pedal axles.

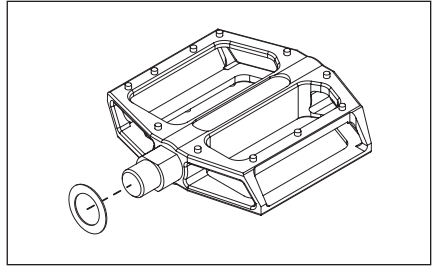

2. Turn the left pedal counterclockwise into the thread in the left crank arm and tighten the pedal with a tightening torque of 35 Nm.

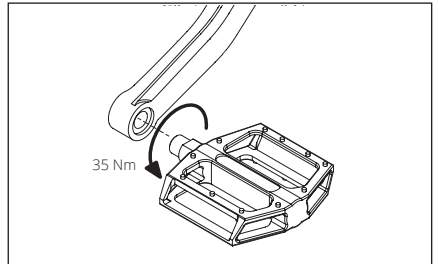

3. Turn the right pedal clockwise into the thread in the right crank arm and tighten the pedal with a tightening torque of 35 Nm.

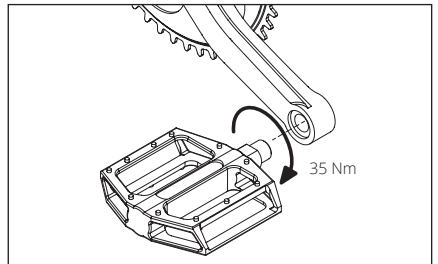



## 4. BEFORE THE FIRST RIDE

### PREPARATIONS

- The bike has been assembled to a roadworthy condition (see „3. Assembling the bike“ on page 11).
- The seat height is adjusted to allow comfortable riding and safe getting on and off the bike (see „3.4 Adjusting the saddle height“ on page 14).
- The required activities are performed from „5.1 Before the ride“ on page 18.

### ACTIVITIES BEFORE THE FIRST RIDE

1. Familiarise yourself with the handling, brakes, shifting system and – if available – with the suspension elements of your bike, while not on public roads. Do not forget to wear a helmet! Only slowly increase the demand of the terrain or riding maneuvers.
2. Brake in the brake pads.  
Choose a road away from public traffic and slow down from 30 km/h to 5 km/h 20 to 30 times. Braking should be as hard as possible without skidding. Then repeat the procedure for the second brake. Only then the brake can develop its full braking force.  
Please note the brake manufacturer’s instructions for more information. In case of deviations, the manufacturer’s specifications must be observed.
3. Check the function of the brakes while riding.  
Practice braking in safe terrain first until you have some feeling for the brakes. The braking point and braking dosage can be different for each bike. You must instinctively know how and which brake is operated with the respective lever.
4. Familiarize yourself with the shifting system.  
Shift through all gears while riding slowly and select an appropriate gear. Practice proper shifting first in safe terrain until you know how the gears work.
5. If special pedals are mounted on your bike, familiarize yourself with them as well. With some system pedals, not only the entry but also the exit takes some getting used to and requires a familiarization phase.
6. Familiarize yourself with the lighting system.  
You need to know how and where to turn on the lights when darkness falls.
7. If you have a bike with suspension systems, have a dealer adjust the suspension.

## 5. ACTIVITIES BEFORE AND AFTER THE RIDE

### 5.1 BEFORE THE RIDE

For the safe use of your bike, the condition of the bike and its components must be checked before riding. If there are any defects or faults, the bike must be checked by your dealer and the defects rectified. Never ride a defective or faulty bike!

	BEFORE THE FIRST RIDE	BEFORE EACH RIDE
Check overall condition of the bike → There are no damages or abnormalities.	X	X
<b>WHEELS</b>		
Check the wheels: Lift the front and rear wheel one after each other and turn the wheels. → The wheels must turn smoothly. → The wheels must turn straight, without lateral or vertical runout. → The tires must not touch the frame at any point	X	X
Check the wheels for hub play: Lift the front and rear wheel one after each other and move the wheels sideways. → There must be no play.		X
Check the freewheel system of the rear hub: Sit on the bike, pull the front brake and pedal with moderate effort while standing. → The power must be transmitted to the rear wheel. → The freewheel must not slip.		X
Check the air pressure in the tires: The air pressure is best checked with a floor pump with pressure gauge. → The minimum and maximum tire pressure specified by the tire or rim manufacturer must not be exceeded or undercut. See „7.2 Tire pressure“ on page 26.	X	X
Check the tires for damage and wear. → There must be no damage. → Wear must not be so advanced that the puncture protection insert or carcass threads are visible on the tread.		X
Check the correct fit of the quick release and thru axles.		X
<b>BRAKES</b>		
Check the braking effect: While standing, pull both brake levers in succession and move the bike back and forth. → The front and rear wheel must lock when the brake is applied.	X	X
Check the degree of wear of the brake pads. → The brake lining on the metallic carrier must have a minimum thickness of 1 mm.		X

	BEFORE THE FIRST RIDE	BEFORE EACH RIDE
Check the degree of wear of the brake disc. → The wear limit is marked on the brake disc.		X
Check brake hoses and connections for brake fluid leakage and defects. → No brake fluid may leak at the hose connections.	X	X

### COMPONENTS

Check the tight fit of the stem: Stand in front of the bike, clamp the front wheel between your knees and try to twist the handlebar. → It must not be possible to twist the handlebar with normal force.	X	X
Check the bearing play of the headset: Stand next to the bike with both hands on the handlebar, pull the front brake lever and slowly move the bike back and forth. → No bearing play must be detectable.	X	X
Check the tight fit of the seat post: Stand behind the bike, grab the saddle with one hand and try to twist it. → The saddle and seat post must not be able to be twisted.	X	X
Check the tight fit of all components. → Loose components must be tightened to the required torque.	X	X

### FRAME

Check the frame for damages and deformations. → There must be no damages.	X	X
Check the fastening of all cables and hoses in the cable clamps. → All cables and hoses must be firmly seated in the cable clamps.	X	X

### SUSPENSION ELEMENTS

Check the suspension elements for damages and abnormalities such as oil leakage. → There must be no damage.	X	X
--	---	---

### LIGHTS AND REFLECTORS (IF AVAILABLE)

Check the lights for function and condition. → Front light, rear light and reflectors are present, undamaged and clean. → Front light and rear light work. → Front light, rear light and reflectors are not hidden by bags or anything else.	X	X
---	---	---

## 5.2 AFTER THE RIDE



### **DANGER**

#### **BRAKE FAILURE OR REDUCTION OF BRAKING FORCE DUE TO DIRTY BRAKE PADS OR BRAKE SURFACES!**

Never apply care products, grease or oil to the brake pads and the brake surfaces! This impairs the braking effect - your safety is at risk! Grease or oil on the brake disc significantly impair the braking effect. The brake pads become unusable.

### **5.2.1 CARE AND CLEANING**

Different materials and mechanisms require thorough care and cleaning. Parts with a limited service life will last longer with regular care and cleaning, but will still show signs of fatigue after a certain amount of time. Cracks and discoloration are signs of such fatigue.

Bicycle cleaning should also serve for inspection. At the same time as cleaning, check the wheel for cracks or scratches, damaged shift and brake cables, material bending, loose spokes, loose bolts and various parts that - if damaged or defective - need to be replaced.

Use a sponge or cloth with clean water to clean the bike. Be careful when cleaning with a high pressure washer! The high-pressure water jet can push past the seals and into the bearings. This flushes out the lubricants, destroying the bearing running surfaces. Especially in winter operation, cleaning should be carried out at shorter intervals so that road salt does not cause any damage.

Be careful when cleaning the chain: Poison for chain maintenance is the use of gasoline, spirit, kerosene or similar. Also avoid cleaning the chain with a pressure washer, this washes out the chain to the last corner and makes the material "dry".

The chain and the moving parts of the gearshift must be lubricated regularly after cleaning (see also „5.2.2 Maintaining the chain“ on page 21). Preserve paint, spokes, metallic surfaces, etc. after cleaning with a spray or hard wax. Protect the metallic parts with a thin film of oil. So-called penetrating oil is ideal for this purpose; it penetrates even the smallest cracks and protects against corrosion there.

Drive belts must not be lubricated or oiled. Here, regular cleaning with clear water is sufficient.

For the care of carbon frames and components, we also recommend cleaning with a bicycle cleaner or soapy water and then sealing the surface with a protective wax spray (e.g. Dynamic protective wax). This protects the pores in the surface of the paint, but also of any raw carbon fiber surfaces, from harmful environmental influences and also facilitates cleaning.

Carbon fiber is sensitive to chafing - therefore, chafing contact points with add-on parts (e.g. brake and traction sheaths) should be protected from chafing by applying a robust polyurethane protective film.

If your bike has suspension elements, special attention should be paid to the cleanliness of the moving parts. Dirt in this area can cause premature wear and thus reduce the performance of your suspension elements.

### 5.2.2 MAINTAINING THE CHAIN

The bicycle chain is the central element in the drive system of a bicycle. Dirt collects on the oily chain and accelerates wear.

For a long life of the chain, the following steps must be performed regularly:

1. Clean the chain with an oil-soaked rag.
2. Oil the chain with chain oil.
3. Wipe off excess oil with a dry, lint-free cloth.

### 5.2.3 PARKING YOUR BICYCLE

Always park your bike safely and protected against falling over. Often, falling over from a standing position onto an edge is enough to permanently damage the frame or components.

Secure your bike with a lock against theft and unauthorized use.

## 5.3 AFTER A CRASH



### **DANGER**

#### **DANGER OF ACCIDENT BY DAMAGED OR BROKEN COMPONENTS!**

Crashes or overstressing can cause unnoticed and invisible damage.

- After a crash or if damage is suspected, the bicycle and its parts must be checked by your dealer.
- Riding with damaged, bent or even torn parts is life-threatening.
- Never straighten bent parts yourself, but replace them for your own safety.

After a crash, overstressing of the components cannot be ruled out. This can result in cracked carbon fibers or deformed aluminum components and limit mechanical strength. Damage is often not visible.

Damage on aluminium parts is indicated by dents, cracks, deformations or discolorations. If one of these signs occurs, the component or the bicycle must not be used any further.

Assessing a carbon component is often very difficult for the layman. Damage does not necessarily have to be clearly visible. A superficial scratch can be an indication that the individual carbon layers have detached from each other.

Any suspected damage must always be examined by your dealer!

## 6. TRANSPORT, STORAGE AND DISPOSAL

### 6.1 TRANSPORT BY CAR



#### WARNING

##### **RISK OF DAMAGE TO THE BICYCLE FRAME DUE TO CLAMPING OF THE FRAME!**

Lightweight aluminum frames and carbon frames must not be clamped in a bike carrier using the usual frame clamps. Such clamps will damage the frame.

- For several Simplon bike models there are clamping adapters available to ensure the clamping forces are transferred well to the bike frame, but don't damage the bike.
- For some SIMPLON bike models, special adapters are available that better distribute the clamping forces of a retaining claw. Find out if an adapter is available for your bike model.

### TRANSPORT IN A CAR

Inside the car, the bike is protected optimally from the weather and theft. But even here there are some points that need to be considered.

- When the wheels are removed, a transport lock must be fitted between the dropouts. Lateral pressure on unsupported rear stays or on the fork can lead to irreparable damage.

### TRANSPORT ON THE CAR REAR OR ROOF RACK

Always observe the operating instructions of the rear or roof rack for specific regulations.

When transporting several bicycles on the rear or roof rack, make sure there is sufficient space or padding between the bicycles. To avoid damage to the coating of the rims, rims must be padded before lashing straps or ratchet systems are attached.

When transporting on a rear carrier, make sure there is sufficient distance between the exhaust and the wheels. Exhaust temperatures can reach several hundred degrees.

### 6.2 STORAGE OF THE BIKE

The bicycle should be parked in a suitable bicycle stand, which ideally only accommodates the rear wheel. Check the air pressure regularly when the bike is parked for long periods of time. The bike should not stand for a long time without air in the tires.

### 6.3 SHIPPING THE BIKE

Only use shipping boxes specifically designed for bicycles.

1. Turn the handlebar so that the brake levers are pointing down.
2. Turn the handlebar through 90 degrees.
3. Fasten all loose or movable parts or wrap them sufficiently. Sharp or pointed components should be wrapped additionally to make sure they won't damage other parts of your bike and won't tear through the outer packaging.
4. Attach a filler cardboard to the rear of the drive side to protect the rear derailleur from pressure from the cardboard and from external impacts.
5. Protect the top tube from damage by the handlebar by using suitable material (e.g. tube insulation).

## 7. MAINTENANCE



### DANGER

#### DANGER OF ACCIDENT DUE TO MAINTENANCE NOT BEING PERFORMED OR NOT BEING PERFORMED ON TIME!

If maintenance is neglected, worn components can lead to accidents.

- The maintenance activities and intervals specified in this user manual must be observed.
- The annual inspections must be performed by your dealer.

The following maintenance activities must be performed at the specified interval.

Component	Activity	monthly*	annually*	other / remark
Screw connections	Check, retighten if necessary	X		see „Torques“
Lacquer, metal parts	Preserve			3 months
Seat post	Dismount and lubricate, check screw connection	X		
Suspension seat post	Check for play	X		
Brake	Inspection of brake discs, brake pads and brake system			see „5. Activities before and after the ride“
Gears	clean and lubricate	X		
	Remove and grease shift/ brake cables		X	
Pedals	Check bearing play	X		
Crank	Check, tighten		X	
Crankset	Check bearing play	X		
Headset bearing	Check bearing play	X		
	grease		X	
Hub bearing	Check bearing play	X		
	grease		X	
Chain	Check / replace			2000 km
Belt	Check tension and wear		X	
Handlebar	Disassemble handlebar, remove grips and control elements, inspect or replace handlebar for damage and nicks, etc.		X	replace after 5 years or after a crash
Stem	Disassemble and grease		X	
Tires	Check tread and tire sidewalls	X		

Component	Activity	monthly*	annually*	other / remark
Wheels	Check run-out and spoke tension	X		
	Check rim wall thickness	X		
Suspension fork	Check air pressure	X		
	Send in for maintenance		X	
Rear shock	Check, check air pressure	X		
	Clean bearing points	X		
	Send in for maintenance		X	

\* The activities with monthly interval can be done by yourself. The prerequisites are the necessary expertise and suitable tools. All other activities must be carried out by your dealer. You should carry out cleaning, care and inspection work yourself on a regular basis (see „5. Activities before and after the ride“ on page 18).



## 7.1 TORQUES

The torque specifications on the respective components and from the following table must be strictly observed. If these are exceeded, components can be damaged or destroyed, which can lead to failures in riding operation immediately or over time with dire consequences for accidents. We recommend having safety-relevant screw connections performed at a specialist workshop.

### MAXIMUM TORQUE

The maximum torque is a value that must not be exceeded. A lower torque is sufficient for a secure connection normally. Especially when using assembly paste, the torque can often be reduced significantly below this value as the solid particles in the assembly paste significantly increase the friction.

Tip: The lower the tightening torque of the screws, the less stress is placed on the component - this is particularly important for carbon frames and carbon components.

### REFERENCE VALUE

The reference value is not a value to be achieved. This value represents a reference point. In some cases, a clamping effect already occurs below this value.

### TORQUES OF OTHER COMPONENTS

For torques not specified in the table, the instructions of the respective component manufacturers apply.

### SPECIAL NOTES

For connections consisting of two or more bolts (e.g. handlebar stem), tighten the bolts alternately in small increments until all bolts are evenly tightened.

### TORQUE TABLE

Component	Screw connection	Brand and type	Maximum torque	Reference value
Seat post clamp quick release	Quick release	especially with SIMPLON carbon seat posts: Tighten sensitively until secure against twisting, use assembly paste		
Shift / brake lever road bike	Clamping bolt/ clamp		7 Nm	5 Nm
Front derailleur clamp	Clamping bolt/ clamp		7 Nm *	5 Nm *
Bottle cage	Mounting screws	SIMPLON	5 Nm	3 Nm

\*When using carbon components or on carbon frames, we recommend the use of assembly paste with solid particles. This increases friction, which leads to the achievement of torsional stability at much lower torque and thus to a reduction in the load on the component.

## 7.2 TIRE PRESSURE

The maximum tire pressure depends on the tire width and the inner width of the rim. When making adjustments to the tire pressure, you can use the following table as a guide. The maximum tire pressure must not be exceeded under any circumstances!

For bicycles with original tires, the maximum tire pressure can be determined based on the tire width. You can find the tire width on the sidewall of the tire.

On many bicycles, it makes sense to select a tire pressure lower than the maximum pressure for the sake of riding comfort. The minimum tire pressure is also marked on the tire sidewall and should not be undercut.

Rim width (inside width)						Recommended tire width		Maximum tire pressure		
						[mm]	[Inch]	[bars]	[psi]	
						18	0.7	9.8	142	
						20	0.8	9.3	135	
17 mm						23	0.9	8.8	128	
						25	1	8.3	120	
						28	1.1	7.6	110	
						30	1.2	7.0	102	
						32	1.25	6.6	96	
						35	1.35	5.8	84	
						37	1.4	5.5	80	
						40	1.5	5.3	77	
						42	1.6	5.0	73	
						44	1.7	4.8	70	
19 mm						47	1.8	4.5	65	
						50	1.9	4.2	61	
						52	2	3.9	57	
						54	2.1	3.6	52	
						57	2.2	3.3	48	
						60	2.3	3.0	44	
						62	2.5	2.7	39	
						66	2.6	2.5	36	
						69	2.7	2.3	33	
						71	2.8	2.1	30	
21 mm						74	2.9	1.9	28	
						76	3	1.8	26	
						81	3.2			
						89	3.5			
	23 mm									
25 mm										
27 mm										
29 - 40 mm										

